

FERNI SERIES

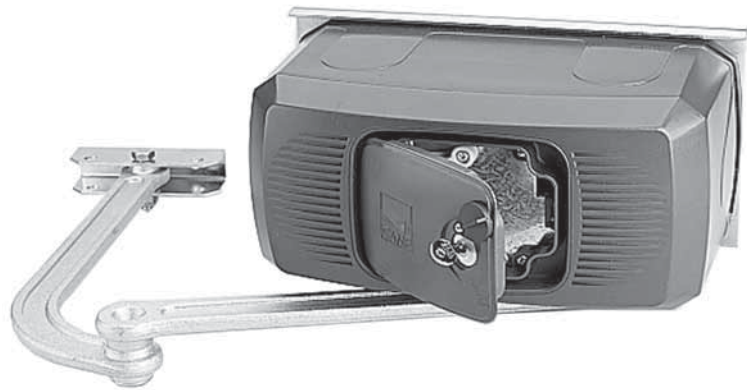

INSTALLATION MANUAL

F1024 N

"IMPORTANT INSTALLATION, SAFETY INSTRUCTIONS"

"CAUTION: IMPROPER INSTALLATION MAY CAUSE SERIOUS DAMAGE, FOLLOW ALL INSTALLATION INSTRUCTIONS CAREFULLY"

"THIS MANUAL IS ONLY FOR PROFESSIONAL OR QUALIFIED INSTALLERS"



1 Legend of symbols



This symbol tells you to read the section with particular care.



This symbol tells you that the sections concern safety issues.



This symbol tells you what to say to the end-users.

2 Intended use and restrictions

2.1 Intended use

The FERNI 24V N operator is specifically engineered to automate residential and condominium swing gates, even under intensive use.

2.2 Restrictions

The use of this product for purposes other than those described above and installation executed in a manner other than as instructed in this technical manual are prohibited.

3 Reference Standards

The company: CAME cancelli automatici is ISO 9001:2000 quality certified; it has also obtained the ISO 14001 environmental safeguarding certification. CAME engineers and manufactures all of its products in Italy.

This product complies with the following standards: EN 12978, UNI EN 954-1, CEI EN 60335-1, UNI EN 12453.

4 Description

4.1 Gearmotor

This product is engineered and manufactured by CAME CANCELLI AUTOMATICI S.p.A. and complies with current safety regulations. Guaranteed 24 months if not tampered with.

The gearmotor is composed of two, cast aluminium half shells inside of which rest the gearmotor and endstops – with electro blocking – and an endless screw, epicycloidal gear reduction system.

4.2 Technical features

Control board power supply: 230 A.C. 50/60Hz

Motor power supply: 24V D.C.

Max draw: 4A

Power: 100W

Opening time (90°): adjustable

Gear ratio: 1/36

Duty Cycle: Intensive use

Protection Rating: IP44

Weight: 7,5 kg

Operating temperature



4.3 Description of parts

- 1) Base plate
- 2) Gearmotor assembly
- 3) Motor cover
- 4) semi-arm

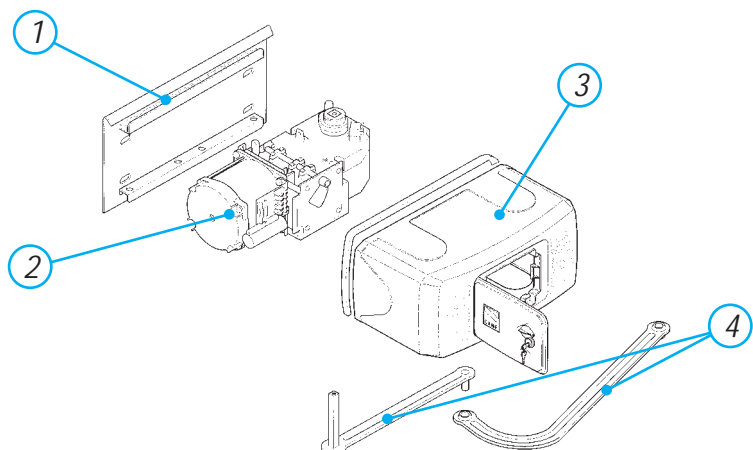

4.4 Overall dimensions

Measurements in mm

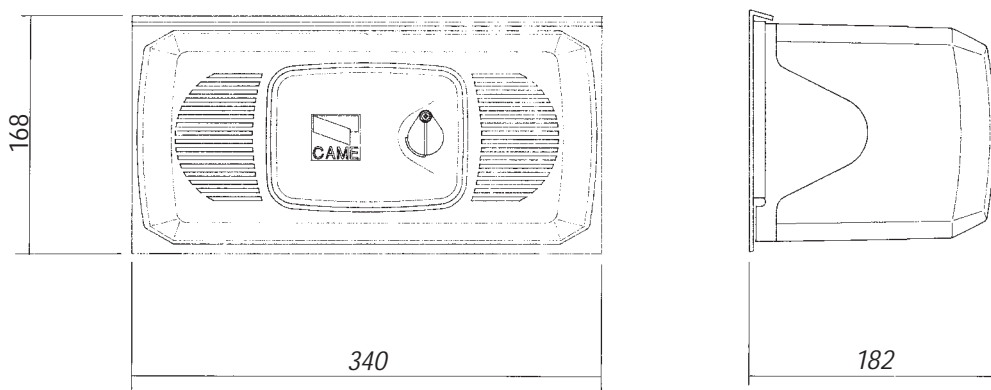

5 Installation

 Installation must be carried out by expert qualified personnel and in full compliance with current regulations.

5.1 Preliminary checks

 Before installing, do the following:

- Make sure the structure of the gate is sturdy, the hinges work and that there is no friction between moving and non-moving parts;
- That measurement C is not greater than the value shown in Tab. 3, p. 4. In which case you need to work on the pillar until said measurement is obtained;
- Make sure the path of the electrical cables complies with the command and safety instructions;
- That there is a (soundly secured to the ground) mechanical stop to prevent the gate leaf/gearmotor from over extending
-  You may perform internal back up circuit connections, provided you use additional insulation when compared to the other internal live parts;
- Make sure you have suitable tubing and conduits for the electrical cables to pass through and be protected against mechanical damage.

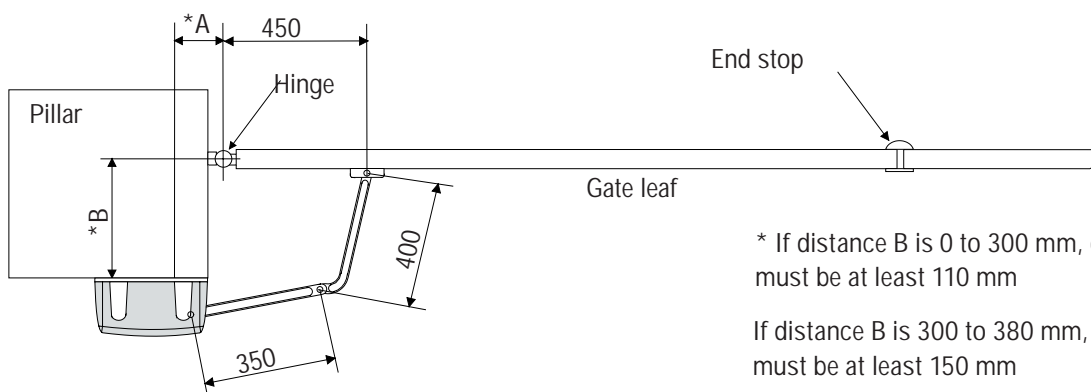

* If distance B is 0 to 300 mm, distance A must be at least 110 mm

If distance B is 300 to 380 mm, distance A must be at least 150 mm

5.2 Tools and materials

Make sure you have all the tools and materials you will need for the installation at hand to work in total safety and compliance with the current standards and regulations. The following figure illustrates the minimum equipment needed by the installer.

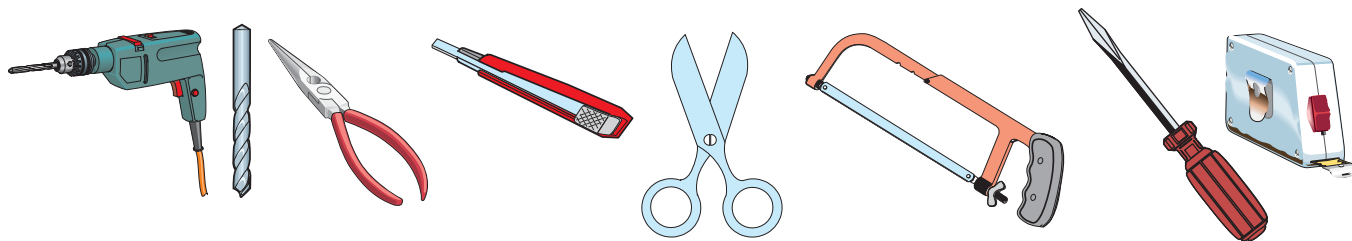

5.3 Cable list and minimum thickness

Connections	Type of cable	Length of cable 1 < 10 m	Leng. cable 10 < 20 m	Leng. cable 20 < 30 m
Control panel power supply 230V 2F	FROR CEI 20-22 CEI EN 50267-2-1	3G x 1,5 mm ²	3G x 2,5 mm ²	3G x 4 mm ²
Flashing light 230V		2 x 0,5 mm ²	2 x 1 mm ²	2 x 1,5 mm ²
Photocell transmitters		2 x 0,5 mm ²	2 x 0,5 mm ²	2 x 0,5 mm ²
Photocell receivers		4 x 0,5 mm ²	4 x 0,5 mm ²	4 x 0,5 mm ²
24V Accessories power supply		2 x 0,5 mm ²	2 x 0,5 mm ²	2 x 1 mm ²
Command buttons		2 x 0,5 mm ²	2 x 0,5 mm ²	2 x 0,5 mm ²
Endstop		3 x 0,5 mm ²	3 x 1 mm ²	3 x 1,5 mm ²
Encoder plug	2402C 22AWG	max. 30 m		
Antenna connection	RG58	max. 50 m		

N.B.: If the cable length differs from that specified in the table, then you must determine the proper cable diameter in the basis of the actual power draw by the connected devices and depending on the standards specified in CEI EN 60204-1.

For connections that require several, sequential loads, the sizes given on the table must be re-evaluated based on actual power draw and distances.

5.4 Standard installation

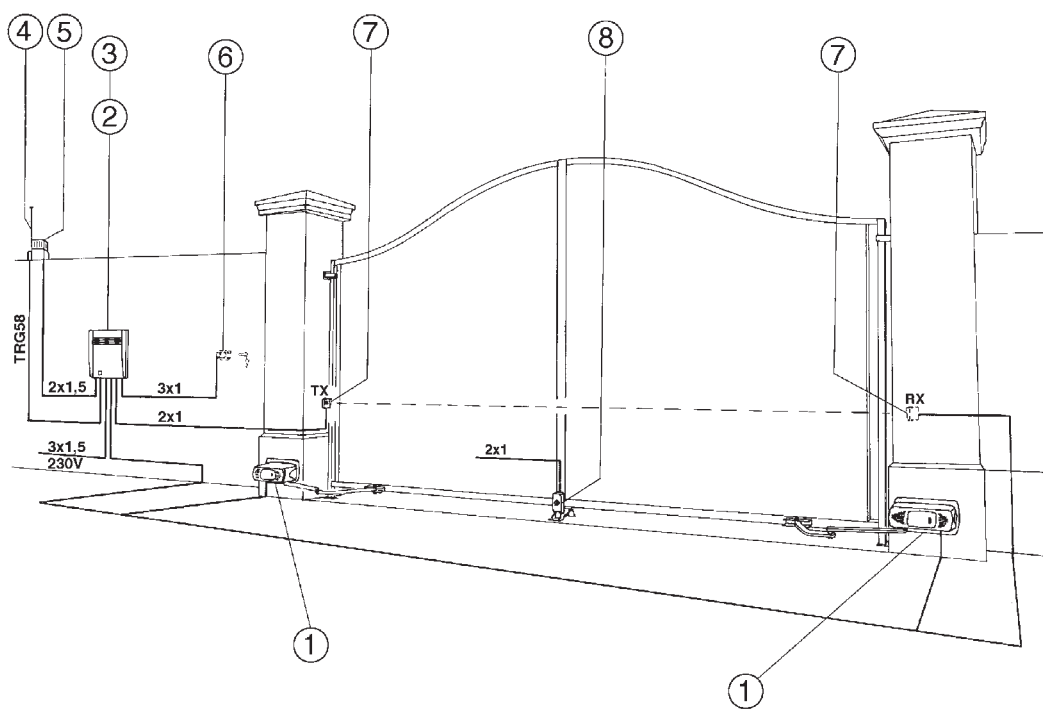

- 1 - Operator
- 2 - Control panel
- 3 - Radio receiver
- 4 - Antenna
- 5 - Flashing light
- 6 - Selector switch
- 7 - Photocells
- 8 - Electric lock

The data and information shown in this manual may be changed by CAME cancelli automatici s.p.a. at any time without prior warning.

5.5 Mounting

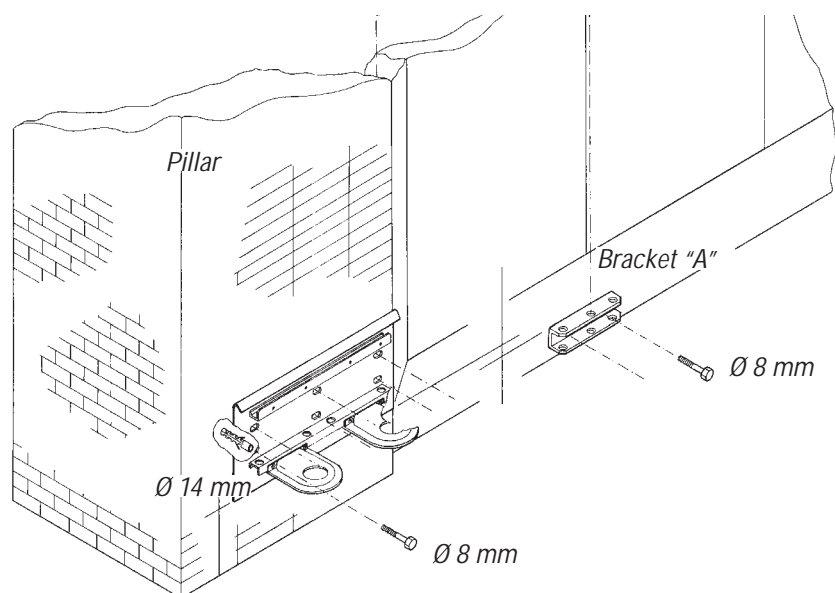

- secure the base plate to the pillar using $\varnothing 8$ screws and $\varnothing 14$ moulded inserts making sure the minimum distance of 150mm from the ground is met.
- Secure the A bracket (using $\varnothing 8$ screws or by welding) to the gate leaf making sure the 450mm and 19mm distances measurements and are met.

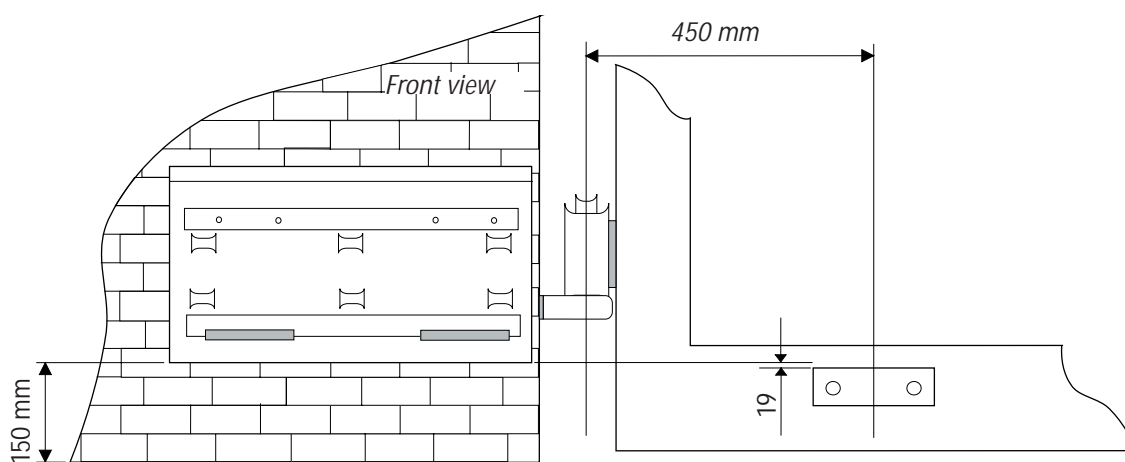

- Insert the gearmotor into the base plate and secure it using the two supplied M8x110 screws and M8 nuts.

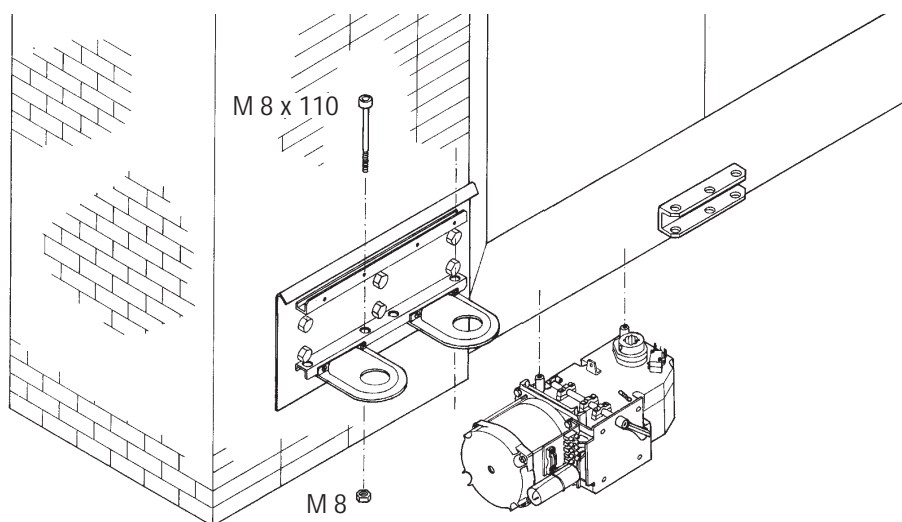

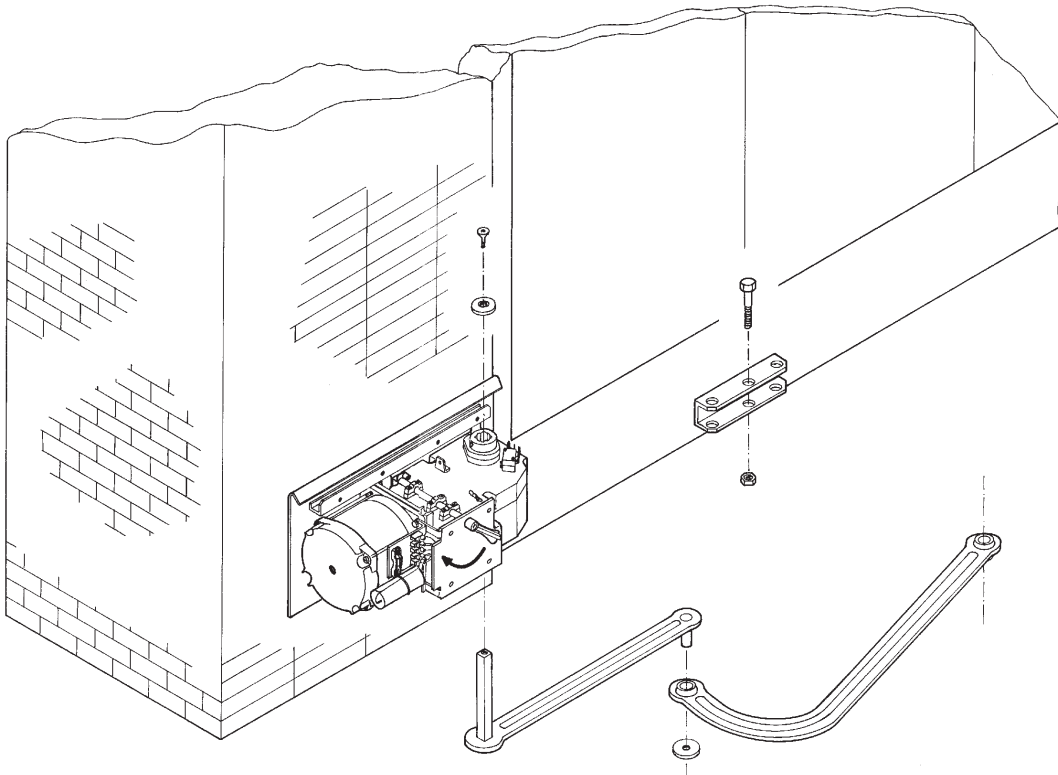

- Insert the straight semi-arm into the motor shaft. Apply the flared washer, the M6x20 screw and lock the semi-arm using the two grub screws.

Join and secure the two arms using the washer and M8x16 screw. Release the motor (see p. 13) and secure the curved semi-arm to the "A" bracket using the M12X50 screw and the M12 nut making sure it runs freely. For right-hand application see fig. 2.

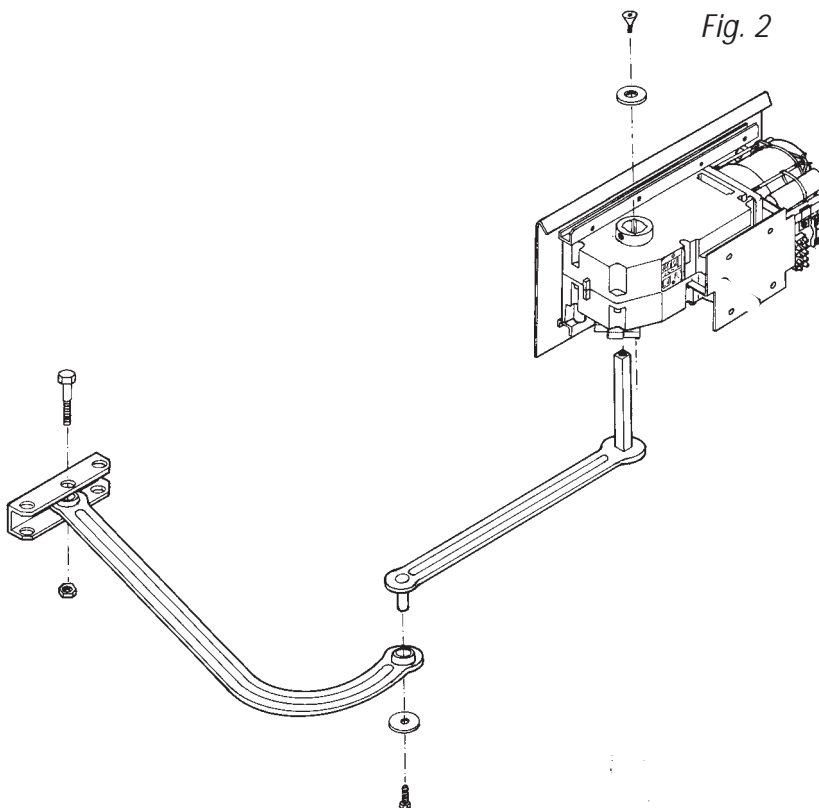

5.7 Adjusting the closing and opening-speed brake microswitches

Opening: release the gearmotor and lead the gate leaf 500 mm from the fully open position. Turn the upper cam until the microswitch is inserted and tighten the screw found on the cam.

Closing: release the gearmotor and lead the gate leaf 500 mm from the fully closed position. Turn the lower cam until the microswitch is inserted and tighten the screw found on the cam.

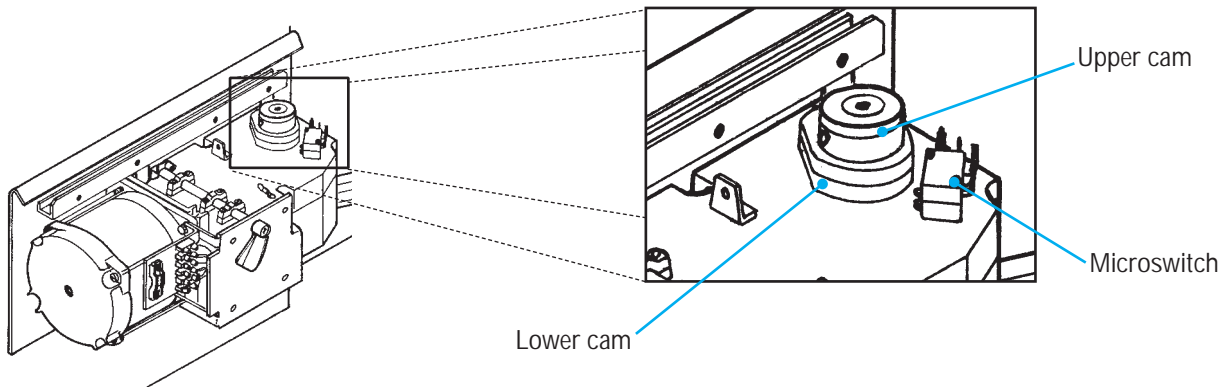

When performing the next, required, electronic adjustment of the closing space, please consult the technical documentation of the installed CAME control panel.

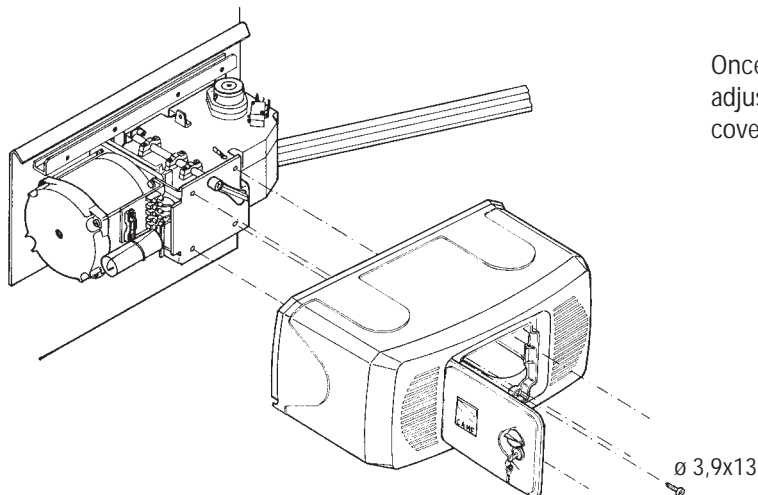

Once finished with mounting, electrical connections and adjustments, lock the motor back into place and replace the cover securing it with the 4 issued screws.

5.8 Manually releasing the motor - Carry out when motor is not in operation

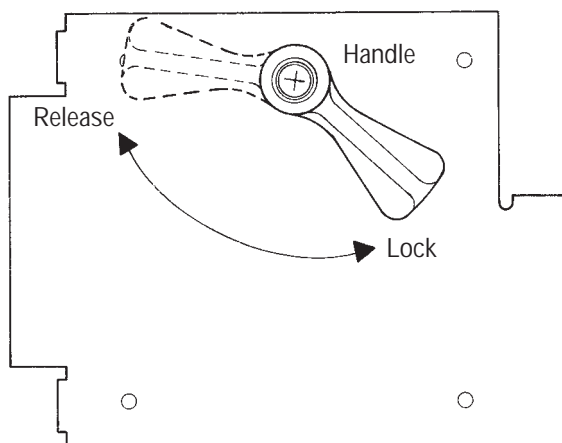

In the event of power outages or breakdowns, release the gearmotor using the opposite handle.

5.9 Connecting to the ZL180 control panel

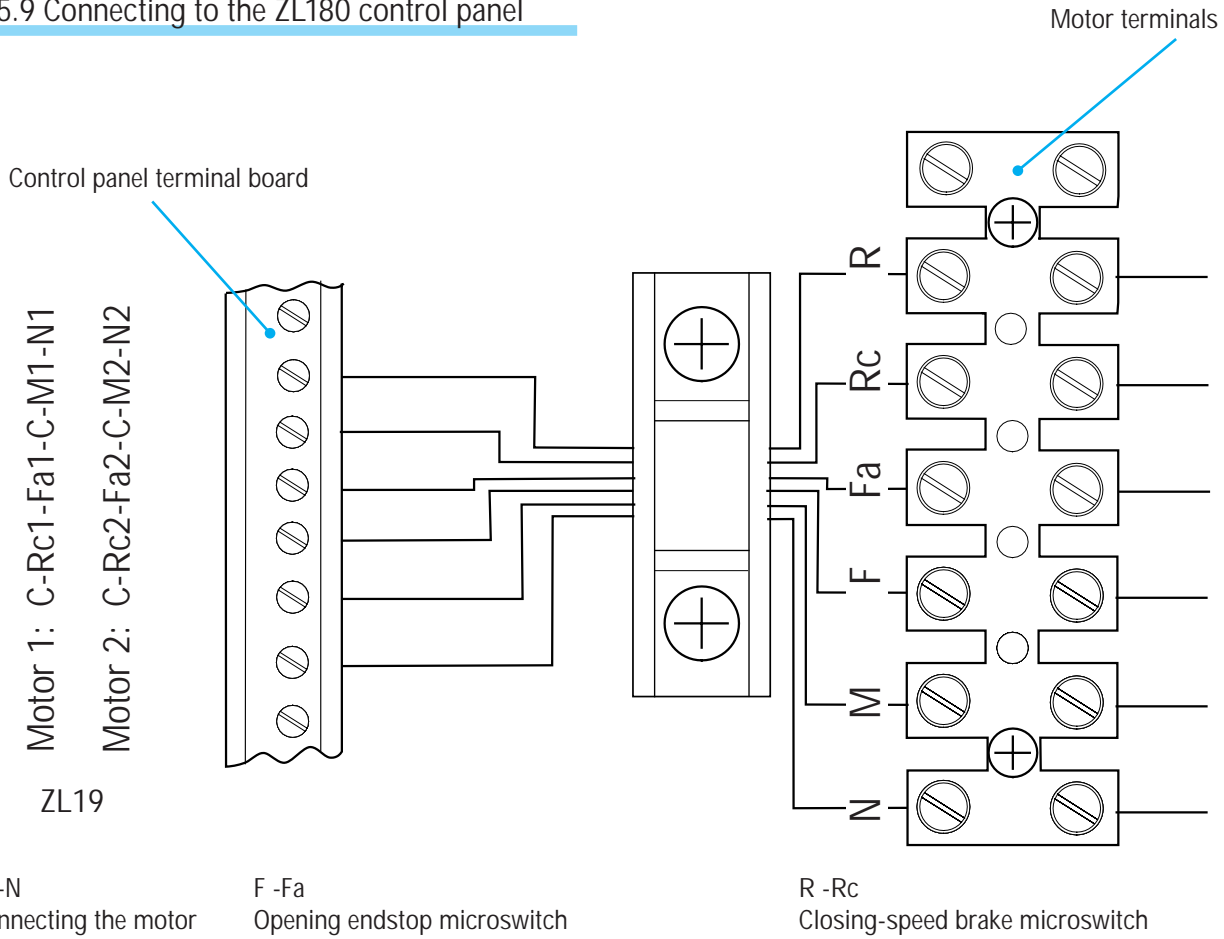

6 Safety instructions

⚠ Important safety instructions

This product must only be employed for its originally intended use. Any other use is wrong and potentially dangerous. The manufacturer cannot be held liable for any damages resulting from wrongful, erroneous or negligent uses.

Avoid working close to the hinges or other moving mechanical parts. Stay out of the opening/closing arc when operator is in motion.

Do not exercise force against the motion of the operator as this could result in potentially dangerous situations.

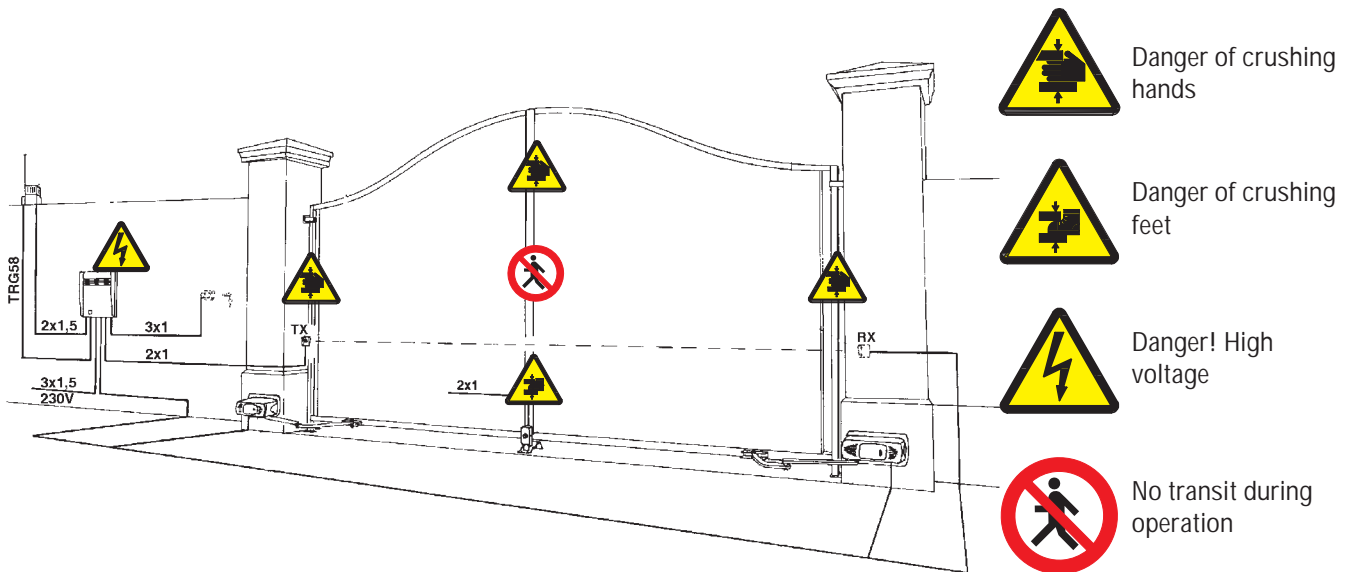

Do not allow children to play or loiter within the opening/closing arc of the operator. Keep remote controls and any other command device out the reach of children, to prevent operator from being activated by accident.

In the event of anomalous behaviour, stop using the operator immediately.

7 Maintenance

7.1 Maintenance

 Periodic maintenance to be carried out by the end-user is as follows: wipe clean the glass surface of the photocells; check that the safety devices work properly; remove any obstructions.

We suggest checking the state of lubrication and tightness of the anchoring screws on the operator.

To check the efficiency of the safety devices, move an object in front of the photocells when gate is closing. If the operator inverts the motion or stops, the photocells are working properly.

This is the only maintenance procedure to be carried out with the power source connected.

Before performing any maintenance procedures, cut off the main power, to prevent possible accidents due to gate movement.

To clean the photocells use a water dampened cloth. Do not use solvents or other chemical products which may ruin the devices.

In the event of any strange vibrations or squeaking, lubricate the joints with grease, as shown in the diagram.

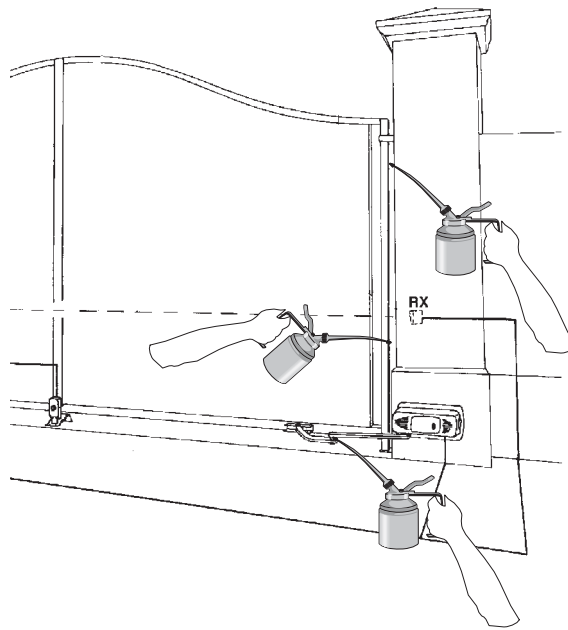

Make sure there are no plants within the photocell's beam, and that the gate motion is free of any obstacles.

7.2 Trouble shooting

MALFUNCTIONS	POSSIBLE CAUSES	CHECK AND REMEDIES
The gate will not open nor close	<ul style="list-style-type: none">• There is no power• The gearmotor is released• The transmitter's batteries are run down• The transmitter is broken• The stop button is either stuck or broken• The opening/closing button or the key selector are stuck	<ul style="list-style-type: none">• Check that the power is up• Call assistance• Replace batteries• Call assistance• Call assistance• Call assistance
The gate opens but will not close	<ul style="list-style-type: none">• The photocells are engaged	<ul style="list-style-type: none">• Check that photocells are clean and in good working order• Call assistance
The flasher does not work	<ul style="list-style-type: none">• The bulb is burnt	<ul style="list-style-type: none">• Call assistance

Installer's stamp	Operator name
	Date of job
	Technician's signature
	Requester's signature
Job performed _____ _____	
Installer's stamp	Operator name
	Date of job
	Technician's signature
	Requester's signature
Job performed _____ _____	

8 Phasing out and disposal



CAME CANCELLI AUTOMATICI S.p.A. employs a UNI EN ISO 14001 certified and compliant environmental protection system at its plants, to ensure that environmental safeguarding.

We ask you to keep protecting the environment, as CAME deems it to be one of the fundamental points of its market operations strategies, by simply following these brief guidelines when disposing:



DISPOSING THE PACKING MATERIALS

The packing components (cardboard, plastic, etc.) are solid urban waste and may be disposed of without any particular difficulty, by simply separating them so that they can be recycled.

Before actions it is always advisable to check the pertinent legislation where installation will take place.

DO NOT DISPOSE OF IN NATURE!



DISPOSING OF THE PRODUCT

Our products are made using different types of materials. The majority of them (aluminium, plastic, iron, electric cables) can be considered to be solid urban waste. They may be recycled at authorised firms.

Other components (electrical circuit board, remote control batteries etc.) may contain hazardous waste.

They must, thus, be removed and turned in to licensed firms for their disposal.

Before acting always check the local laws on the matter.

DO NOT DISPOSE OF IN NATURE!

9 Conformity declaration



MANUFACTURER'S DECLARATION OF CONFORMITY

Pursuant to annex II B of the Machinery Directive 98/37/EC



CAME Cancelli Automatici S.p.A.
via Martiri della Libertà, 15
31030 Dossan di Casier - Treviso - ITALY
tel (+39) 0422 4940 - fax (+39) 0422 4941
internet: www.came.it - e-mail: info@came.it

--- STANDARDS ---

EN 13241-1

EN 12453

EN 12445

EN 12635

EN 12978

EN 60335-1

EN 61000-6-2

EN 61000-6-3

Declares under its own responsibility that the equipments for automatic garage doors and gates listed below:

F 1024 N

... comply with the National Law related to the following European Directives and to the applicable parts of the following Standards.

---DIRECTIVES---

98/37/CE - 98/79/CE

98/336/CEE - 92/31/CEE

73/23/CEE - 93/68/CE

89/106/CEE

MACHINERY DIRECTIVE

ELECTROMAGNETIC COMPATIBILITY DIRECTIVE

LOW VOLTAGE DIRECTIVE

CONSTRUCTION PRODUCTS DIRECTIVE

IMPORTANT WARNING!

Do not use the equipment specified here above, before completing the full installation in full compliance with the Machinery Directive 98/37/EC

MANAGING DIRECTOR
Mr. Andrea Menuzzo

Reference code to request a true copy of the original: DDF B EN A001C

CAME UNITED KINGDOM LTD
UNIT 3, ORCHARD BUSINESS PARK
TOWN STREET, SANDIACRE
NOTTINGHAM - NG10 5BP - U.K.

Tel - 0044 115 9210430

Fax - 0044 115 9210431

